

ANKE - The Reliable Medical Equipment Manufacturer



ANATOM A200 32-slice spiral CT

Proposal

ANATOM A200 32-slice Spiral CT Performance

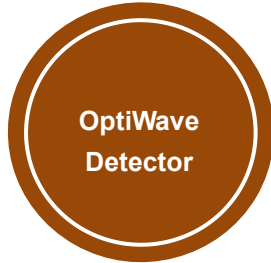

ANATOM A200 adopts ANKE's self-developed new generation OptiWave detector, which is organised and supported by the Ministry of Industry and Information Technology of the People's Republic of China. It is designed with an isofocal hardware structure, combined with the AccuShape^{3D} stereoscopic anti-scattering grids, so that the distance from the X-rays to the corresponding receiving unit of the detector is the same. In addition of obtaining high quality, high resolution images, it also achieves wider body coverage with high pitch in spiral scanning, which not only improves examination efficiency but also enriches clinical applications.

Field replaceable unit (FRU) design, the key parts be easily disassembled, all are in order to achieve the purpose of simplifying the maintenance operation and reducing the maintenance time. Each detector module can be independent of disassembly and replacement which makes the detector module maintenance and system upgrades completed quickly at the scene. It can reduce the user's operation and maintenance costs, on the other hand, ensure the equipment with continuous upgrading ability.

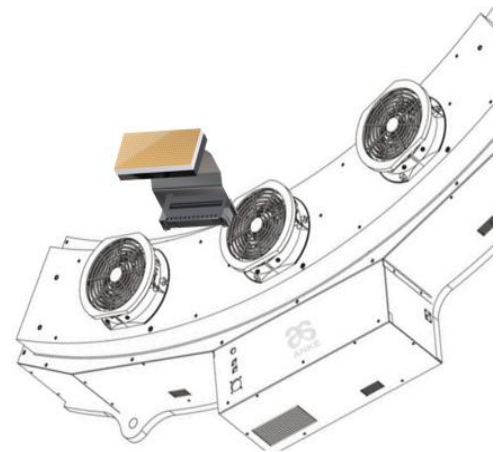

Under the same conditions, the service life of the CT detector depends on the decay

amplitude of the output signal induced by accumulated exposure dose over time. OptiWave detector has been designed of the optimal structure, even after 10 years of use, the radiation damage caused by signal attenuation is less than

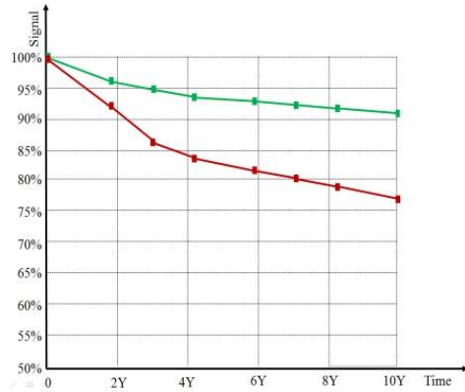

8%. It not only prolongs the service life of the detector but also ensures the users' maximum return on investment.



"sky-eye" camera can intelligently recognize the 2D center of the scan range and automatically aligns it with the isocenter. With one click, AccuPositioning

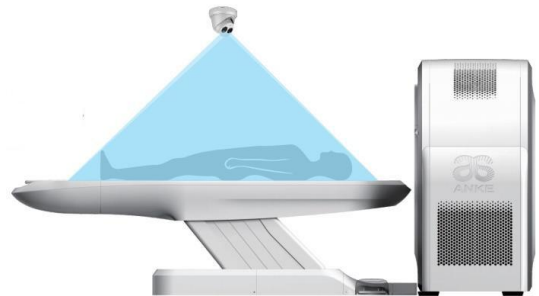

uses all of this information to automatically center your patient for a completely hands-free positioning experience. System is enable the system to intelligently identify multiple positioning points on the human body and display the scanning site on the



Center recognition

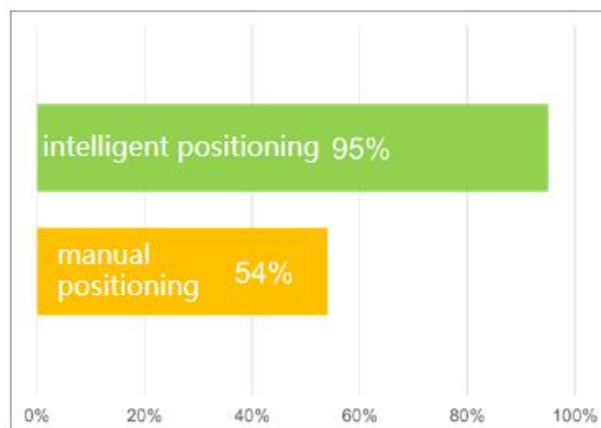

intelligent positioning advantage

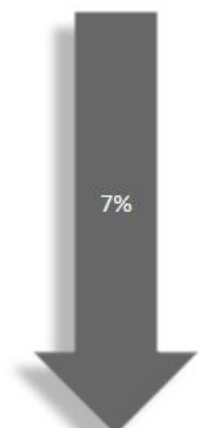

image noise

intelligent touch screen terminal. As well it enables automatically identify the isocentric position of the proposed scanning site to achieve precise and intelligent patient positioning. Through the application of this technology, it not only substantially improves the accuracy of patient positioning and reduces operational errors, but also better protects patients from the risk of collision and accidental injury. More importantly, the AccuPositioning system also helps the technician to standardise operations and mitigate the increase in radiation dose to the patient's surface due to inaccurate positioning, while further reducing image noise, reducing artefacts and improving image quality.



Gantry's built-in camera- "Eagle Eye" allows real-time monitoring of the patient's status, together with the AI-based AccuClear function, and enables intelligent real time image artifact correction. The novel design of the built-in camera allows for both remote observation of the person being examined and also real-time motion recognition. With AI, correction of motion artefacts can be performed.



It is particularly helpful for scanning patients who have involuntary movements, subconscious movements, etc.



ANATOM A200 adopts high precision and double closed-loop feedback system. One million feedback signal will be obtained in a single circle, which ensures precise control of the system for rotary motion with a resolution of 0.00036 degrees. At the same time, the rotating drive control part can

adjust the speed according to the feedback data, and guarantee the system to run smoothly in the 5/1000 deviation range. In addition, the system can adjust the position of the scanning frame in real time according to the read position feedback information, so as to ensure accuracy of the rotation angle

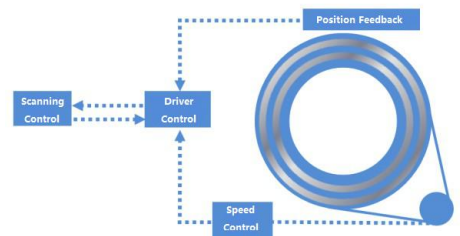

ANATOM A200 has been designed to retain the safety factor of 12 times, providing more than 10 years of service life.

AccuSlip-ring of ANATOM A200 with a new design and new material, compared with the traditional CT, is more stable and abrasion resistance, so that the service life of the carbon brush is 1.5 times higher than the traditional techniques. The slip-ring & carbon brush structure of the traditional design need to be



replaced within 2 years, while as replacement cycle of ANATOM A200 can reach more than three years, greatly reducing the hospital daily maintenance cost. AccuSlip-ring of excellent performance, not only to fully guarantee the stability of power and data

transmission between fixed part and the rotating part, but also ensure the normal operation of the equipment cycle and create greater economic benefits for the user.



Traditional HRCT lung scans are based on the conventional scanning protocol to re-select the scan parameters, then apply a large matrix, high voltage, thin layer and bone reconstruction algorithm to obtain good images

Although it can be relatively satisfactory clinical images, but increases scanning time and radiation dose. AccuLung high-resolution lung imaging technology can get excellent lung high-resolution images only with 30% to 40% of conventional radiation dose.

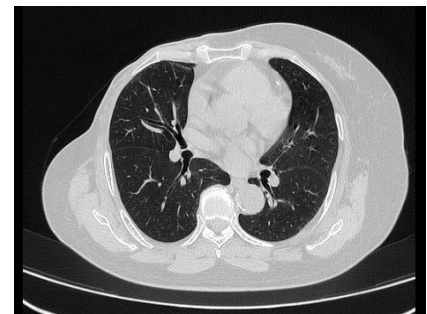

As the inner ear structure is fine, the anatomical morphology and adjacent relationship are complex, different structures interpenetrate each other. In the past, the image inspection technology can not fully display its fine structure. ANATOM A200 is an accurate 32-slice CT with inner ear high resolution

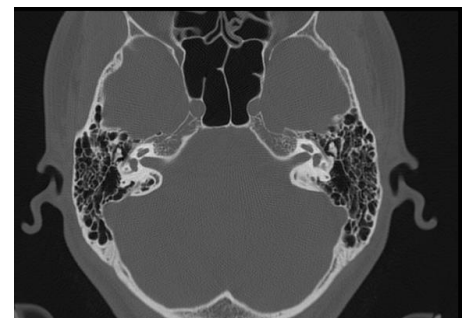

imaging technology to achieve a clear image at any angle and position. This allows the complex inner ear structure to be clearly displayed and realises the true meaning of the anatomical imaging. So that, clinicians have a deeper and more intuitive understanding of the anatomical structure, lesion area, morphology and adjacent relationship of the inner



ear. It provides more accurate image information for diagnosis of disease, development of surgical approach and design of correct surgical plan.

Unique AccuOrgan high-resolution algorithm combined with AccuImage micro-imaging technology has significantly improved abdominal microstructure and morphological display and more accurate image information for early detection of small lesions, differential diagnosis.

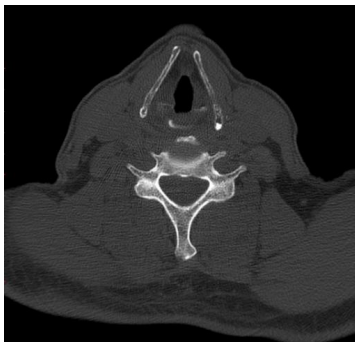
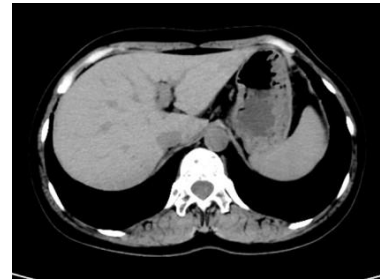

ANKE's unique thin-layer high-resolution imaging technology provides physicians with high-spatial resolution clinical images that enhance the contrast of the edge of the lesion and provide an accurate anatomical relationship to facilitate X-ray easy to miss early under the articular surface of bone destruction, cystic lesions and articular cartilage calcification. In particular, MIP images significantly increased the details of sacroiliac joint disease, such as minor invasion of the articular surface, micro cystic changes.

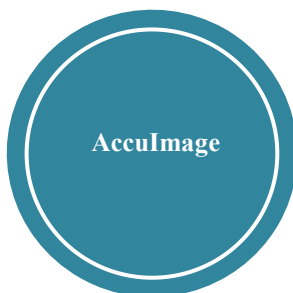

The continuous development of multi-slice CT technology has been making clinical CT quantitative and qualitative diagnosis requirements of increasingly high. It not only requires early detection of lesions, but also requires a clear diagnosis as soon

as possible. Traditional CT image reconstruction matrix is mostly 512×512 , resolution and detail display is relatively limited, for the early detection of small lesions, differential diagnosis is extremely difficult. Our unique Acculmage microscopic imaging technology can increase image quality by 4 times and display more details of the lesion which provides a reliable basis for early detection, early diagnosis and early treatment of clinical disease.



Artifacts caused by the density and structure of the brain have been a blind spot in the brainstem and cerebellar structures and lesions diagnosed by conventional CT.

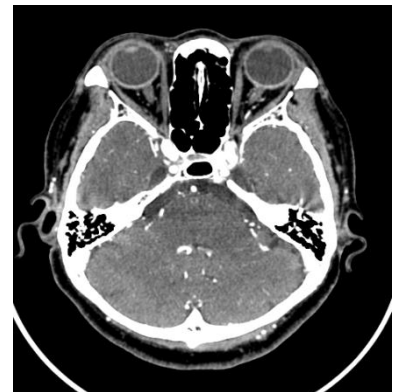

For example, infarcts such as brainstem and cerebellum are not easily displayed due to the influence of artifacts. Of course, these artifacts will also affect the a small amount of hemorrhagic lesions of the diagnosis in posterior cranial fossa. Abast can eliminate the x-ray hardening effect to the cerebellum, brain stem and other parts, clearly to show the structure and improve the reliability of diagnosis

Metal implants in the human body can lead to metal artifacts in CT reconstructed images. The traditional method uses the interpolation technique to replace the metal contaminated data in the original projection data, so as to achieve the

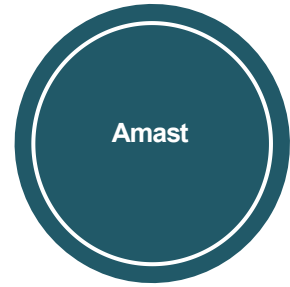

purpose of removing metal artifacts, but easy to produce secondary artifacts. In order to

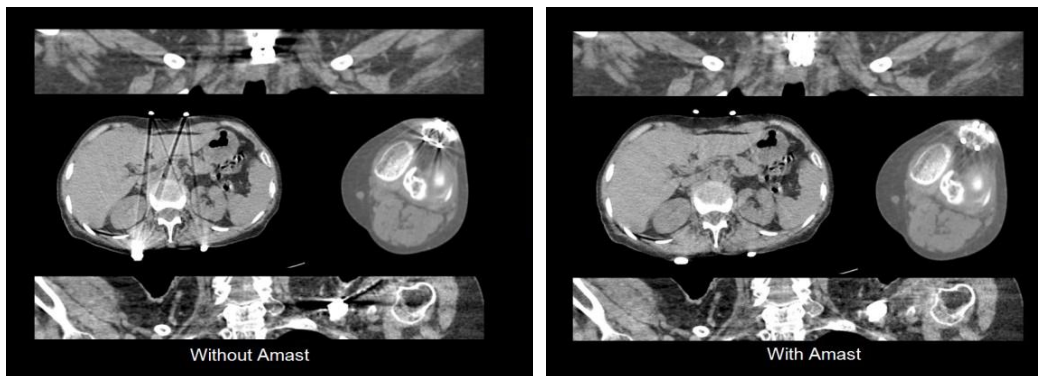

solve the shortcomings of traditional methods, Amast provides a metal artifact elimination method based on iterative correction. Firstly, a preprocessed image is obtained by using the interpolation correction method. Then, iterative correction is performed on the basis of the preprocessed image, and the total image quality is optimised in each iteration process. After several iterations, the final image is obtained. Experiments show that compared with the traditional interpolation method, Amast technology can more effectively remove metal artifacts, and better suppress the generation of secondary artifacts.



ANATOM A200 uses the world leading Admir^{3D} iterative reconstruction technology, through innovative designs of data sampling technology, original data reconstruction technology, post-processing technology and others, Admir^{3D} not only can fully extract the effective data information, but also the data information In the original data field, the corrected projection field and the image field

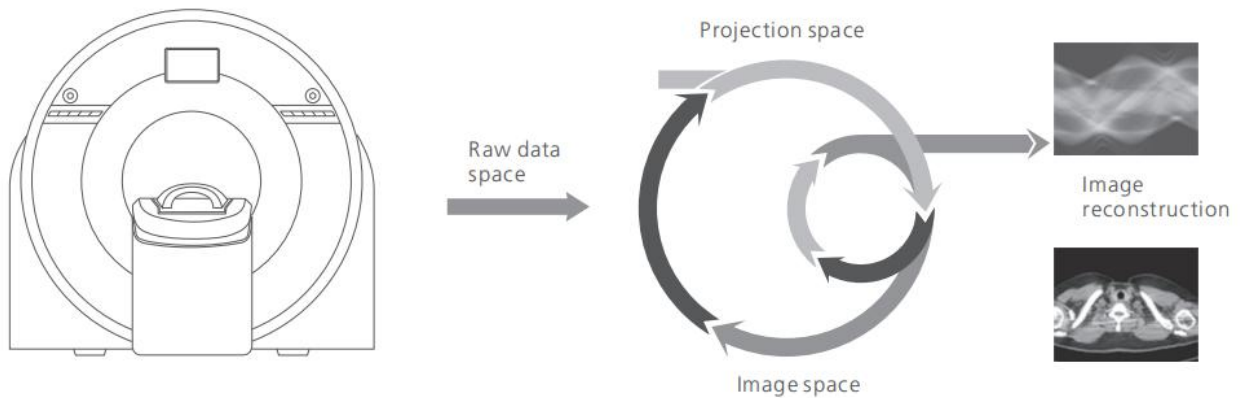

three different data space for multiple recycling, processing, to increase the number of original data reconstruction. That can reduce the X-ray dose and the image noise but Improve the image quality, while access to various parts of high-resolution, low dose of clinical images.

Traditional CT in order to improve the image quality can only be achieved by increasing the dose of X- ray, but at the same time the patient's radiation dose will also be greatly increased. In order to better solve the problem of image quality and radiation dose, Admir^{3D} accurately constructs and describes the photon characteristics of the signal through a unique mathematical model, iterates it in the original data domain, the



corrected projection domain and the image domain. Admir^{3D} processing effect can be performed from 1 to 100 levels, corresponding to the noise reduction requirements.

Admir^{3D} iteration technology is based on the original data field, the projection field after correction and image field, which will no doubt greatly increase the system's computing load. According to this feature, Admir^{3D} platform is equipped with Intel 6-core CPU parallel processor and 32G RAM. Its powerful data processing capability allows the system to mass data processing speed increased nearly 5 times.

AccuOrientation — Intelligent positioning

Preset intelligent positioning procedures, one click for positioning, greatly saving time

AccuEmergency — Emergency mode

New emergency interface, free of registration, quick to start scanning for emergency patients

AccuScanning — Accurate scanning



Default AccuScanning scanning protocol, easy to get high resolution images

AccuTracking — Accurate trigger

Dynamic monitoring of contrast agents in the region of interest, provide accurate scanning delay time to make enhanced scan easy and reduce the repetitive scan

AccuReconstruction — High-speed reconstruction

Up to 30f/second reconstruction speed, 10 times the speed of traditional CT reconstruction, significantly improve the efficiency

AccuPrinting — Quick print

Smart layout and flexible adjustment for printing, automatic printing mode for time saving

Typical Clinical Solutions

Image quality and clinical application are the standards to test the quality of imaging equipment, CT is also the development of focusing clinical needs of continuous innovation and change. Anke has always been adhering to the "Bring science and technology to healthcare" concept to promote the CT technology to leading position in the domestic industry's, and continue to expand the clinical application of new areas. The ANATOM A200 has the most complete clinical applications in the industry. The newest features of the ANATOM A200 include a variety of functions including neurology, orthopaedics, gastroenterology, respiratory, internal medicine, and so on.

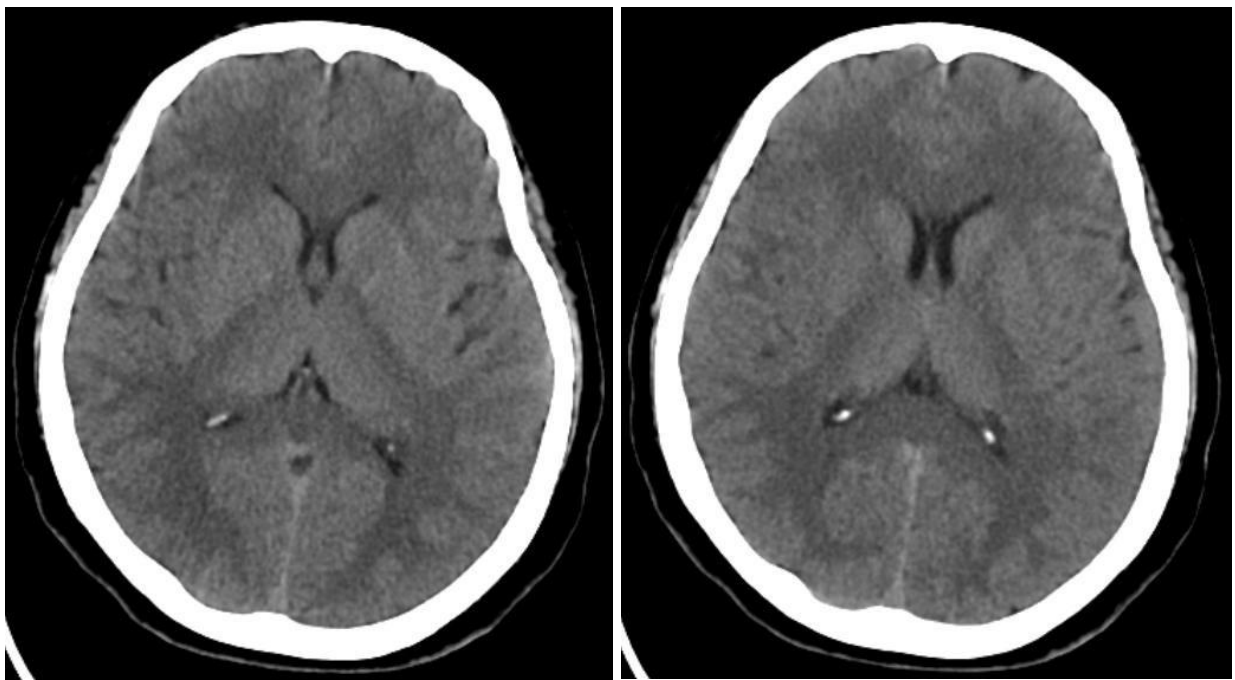

Brain image

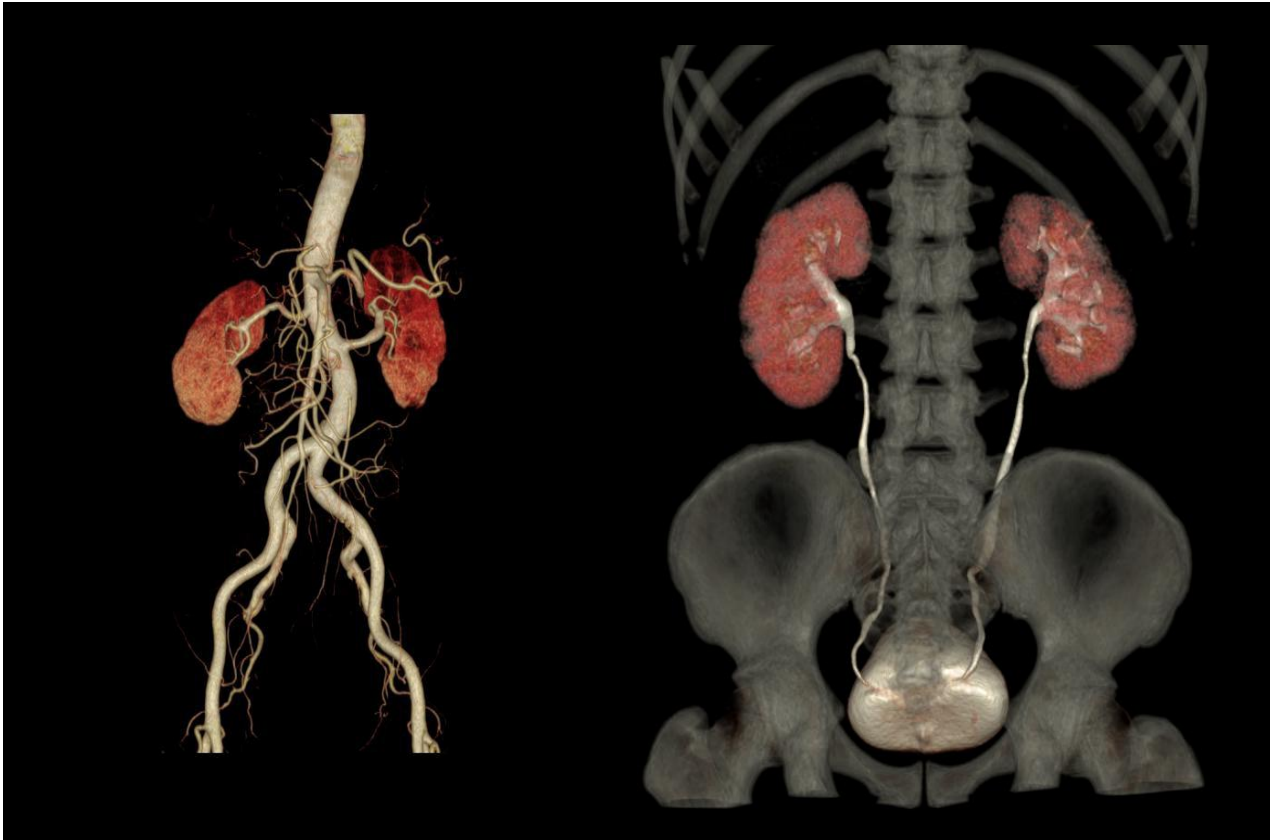

Abdomen CTA and CTU images



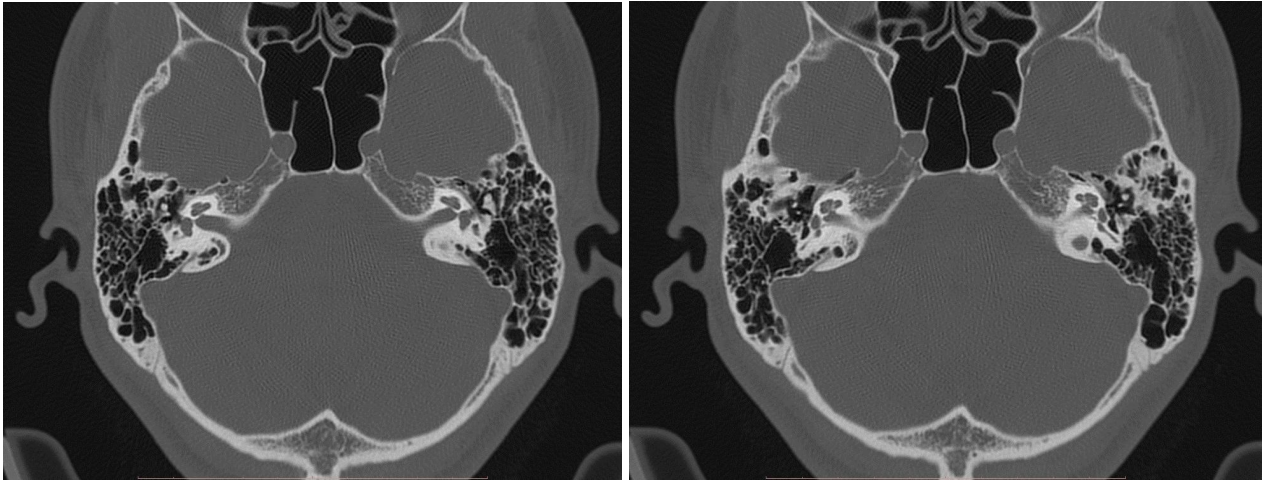

0.55mm inner-ear image

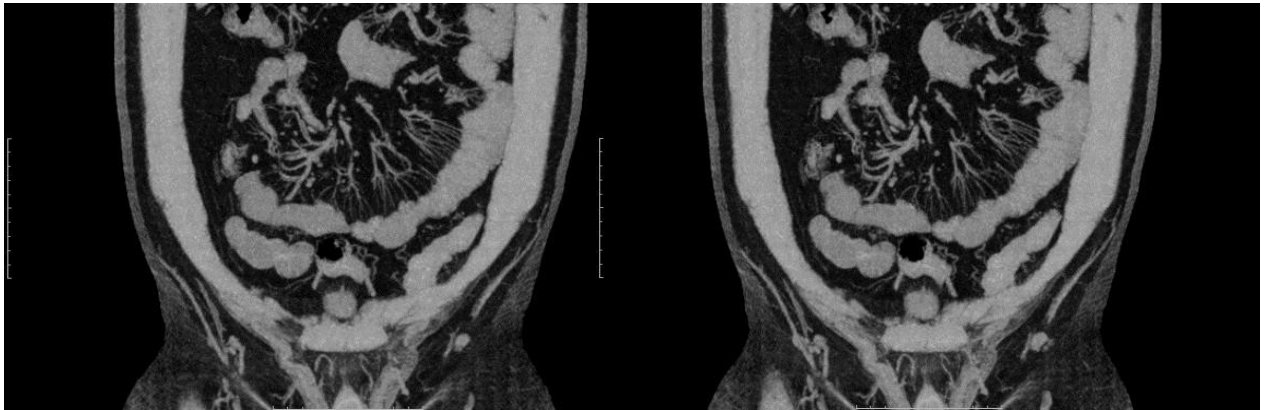

0.55mm abdomen image

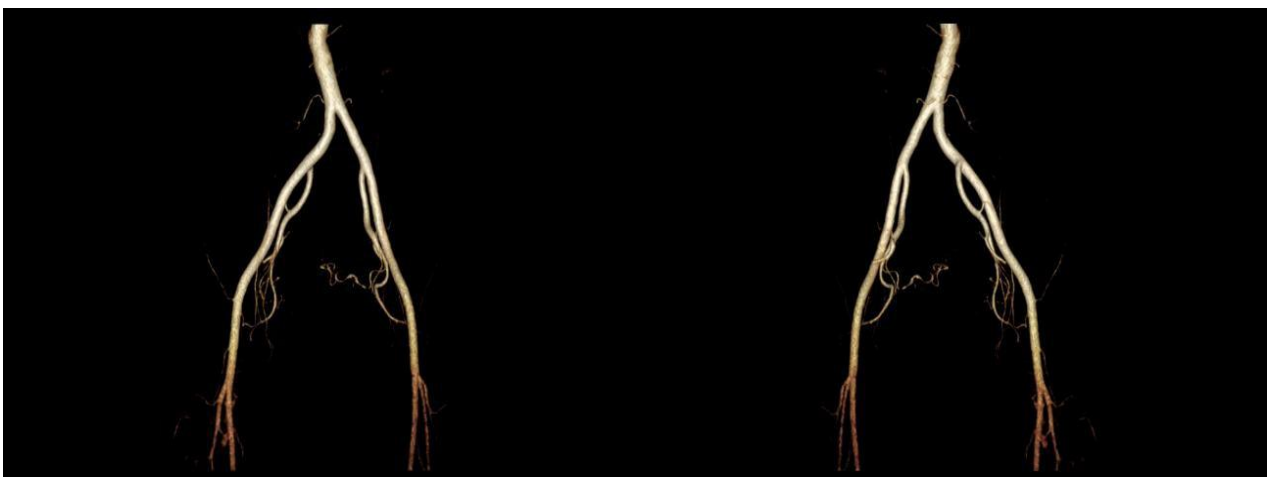

Iliac artery image

Note: some of above mentioned function, technologies and applications are optional, for standard configuration please refer to configuration list.



INSIGHT INTO LIFE

Shenzhen Anke High-tech Co., Ltd.

Address: Block B, LingYa Industrial Zone, Tangtou No.1 Road,
Bao'an District, Shenzhen, 518108, P.R. China

Tel: +86-755-21622518 26688889

Fax: +86-755-26695307 26685908

Email: anke@anke.com

Specifications and appearance of the equipment may change without prior notice. ANKE reserves the right of final interpretation.



Twitter: ANKE (@ankeint)



Facebook: ANKE (@ankemri)



Instagram: ANKE (@ankemarcom)